

# MAXIMUM REACH ENTERPRISES

1853 Wellington Court  
Henderson, NV 89014  
Ph: 702 547 1564  
kent.goodman @ cox.net  
[www.maximumreach.com](http://www.maximumreach.com)

27 August 2014

## PLATE LUG DESIGN WITH A SIDE LOAD

As design engineers, it is our responsibility to make sure that our lug designs meet the latest codes before they are issued for fabrication, but due to the variables in fabrication, installation, field implementation, etc, the designs might not fit right or be used right to code. That is why we use an impact factor (IF) or a safety factor, ie, it is recommended to always use at least a 1.8 IF.

One of the ways that lifting lugs are used outside of code is when the field allows side loading in the weak axis. Very seldom are lugs designed for a side load in the weak axis, so the rule the field should go by is “Do not side load lugs in the weak axis”.

I have checked enough Heavy Lift Contractors (HLC) rigging drawings to know that sometimes their rigging engineers/ superintendents don't think that a little side load in the weak axis on a lug is serious, ie, a lot of HLC use spreader bars that have inserts that bolt together to lengthen or shorten the overall length. The inserts are usually one meter or longer in length, so it is hard to make sure that the lift slings will be vertical. Fluor uses pipe spreader bars with end caps so that the inserts can be cut to length to ensure that the lift slings are vertical.

The purpose of this presentation is to show how to design a plate lug so that it will have reserve strength against side loading in the weak axis. Two examples will be shown, ie, a plate lug used to lift a skid and a plate lug used as a top head lug.

Note that even though the side load in the lug sketches for the following examples is shown to the right or to the left of the lug plate, it can actually be either way and the calculations are still valid.

### **EXAMPLE 1: A plate lug used to lift a skid.**

The printout below shows the design for a plate lug without any side load, but it is the basis for calculating the additional stress that a side load imposes on a plate lug and the weld.

Note that this example is very much like the pad eye lug for #25 Presentation, ie, the dimensions are all most the same as are the forces. The difference is this lug can be attached to an equipment skip with a three or four sided weld group; therefore, the welds are not as critical.

**PROGRAM TO DESIGN A PLATE TYPE LIFTING LUG v.02**

COMPANY:  PROJECT:   
 ITEM NUMBER:

Select a metric shackle from the lookup table based on the force on the lug or click the SHACKLE button to enter your own shackle and lug data.

<input type="text" value="2.88"/>	in	Shackle Inside Width at Pin	
<input type="text" value="4.19"/>	in	Shackle Eye Diameter	
<input type="text" value="2.04"/>	in	Shackle Pin Diameter	
<input type="text" value="2.17"/>	in	Lug Pin Hole Diameter	Recommend hole be 0.13" or > than shackle pin dia.
<input type="text" value="3.50"/>	in	Lug Radius	
<input type="text" value="2.00"/>	in	Lug Plate Thickness	
<input type="text" value="7.00"/>	in	Lug Plate Width at Base	Minimum value of 2*radius of lug
<input type="text" value="5.00"/>	in	Lug Side weld length	Recommend using min. 0.7 * lug plate width
<input type="text" value="0.00"/>	in	Lug Pad Thickness	Input zero if pads are not required
<input type="text" value="0.00"/>	in	Lug Pad Radius	Input zero if pads are not required
<input type="text" value="3.50"/>	in	Lug Eccentricity	
<input type="text" value="40.00"/>	kips	Force on the Lug	
<input type="text" value="60.00"/>	deg	Angle of the Force on the Lug	Measured from the horizontal
<input type="text" value="36.00"/>	ksi	Yield Stress of the Lug Material Fy	
<input type="text" value="14.85"/>	kips/in	Allowable Force on the Weld	Use 10.91 for LH60 or 14.85 for LH70
<input type="text" value="1.80"/>		Impact factor, IF	Recommend that a minimum 1.8 impact factor be used

**OUTPUT:**

**Checking combined stress of the lug plate**

<input type="text" value="14.00"/>	in^2	Area of Lug Plate at Base	
<input type="text" value="16.33"/>	in^3	Section modulus of the lug plate at the base	
<input type="text" value="7.71"/>	ksi	Bending stress of the lug plate fb, actual	
<input type="text" value="4.45"/>	ksi	Tension stress of the lug plate ft, actual	
<input type="text" value="21.60"/>	ksi	Allowable bending and tension stress, Fb & Ft	
<input type="text" value="0.56"/>		Combined stress of the lug plate. Must be less than 1.0	

**Checking the lug weld size for a THREE sided weld, with the weld treated as a line**

<input type="text" value="17.00"/>	in	Area of the weld	
<input type="text" value="2.49"/>	kips/in	Horizontal component of twist	
<input type="text" value="4.31"/>	kips/in	Vertical component of twist	
<input type="text" value="2.04"/>	kips/in	Tension force on the weld	
<input type="text" value="1.18"/>	kips/in	Shearing force on the weld	
<input type="text" value="7.11"/>	kips/in	Resultant Force on the weld	
<input type="text" value="0.86"/>	in	Minimum weld size	

**Checking the lug weld size for a FOUR sided weld, with the weld treated as a line**

<input type="text" value="24.00"/>	in	Area of the weld	
<input type="text" value="1.46"/>	kips/in	Horizontal component of twist	
<input type="text" value="2.53"/>	kips/in	Vertical component of twist	
<input type="text" value="1.44"/>	kips/in	Tension force on the weld	
<input type="text" value="0.83"/>	kips/in	Shearing force on the weld	
<input type="text" value="4.44"/>	kips/in	Resultant Force on the weld	
<input type="text" value="0.54"/>	in	Minimum weld size	

**Checking bearing at the pin hole**

<input type="text" value="17.65"/>	ksi	Bearing stress of the lug without pads	
<input type="text" value="0.00"/>	ksi	Bearing stress with pads attached	
<input type="text" value="32.40"/>	ksi	Allowable bearing stress	
<input type="text" value="0.00"/>	kips	Load per pad	
<input type="text" value="0.00"/>	in	Pad weld size, min.	

**Checking end area of the lug across the pin hole**

<input type="text" value="4.44"/>	in^2	End area required across the pin hole	
<input type="text" value="3.40"/>	in	Maximum effective lug radius. Used to calculate the max. allowable end area	
<input type="text" value="6.94"/>	in^2	Maximum effective end area	

**Checking end area of the lug past the pin hole**

<input type="text" value="2.96"/>	in^2	Area required past the pin hole	
<input type="text" value="4.83"/>	in^2	Actual end area	
<input type="text" value="4.63"/>	in^2	Maximum allowable end area	

The drawing below shows the details of the plate lug that agrees with the printout above and also shows the side load information, ie, 40 kips at a 10° side load angle. Note that bending will be just above the top of the equipment skid, ie, 3.5" down from the centerline of the lug hole.

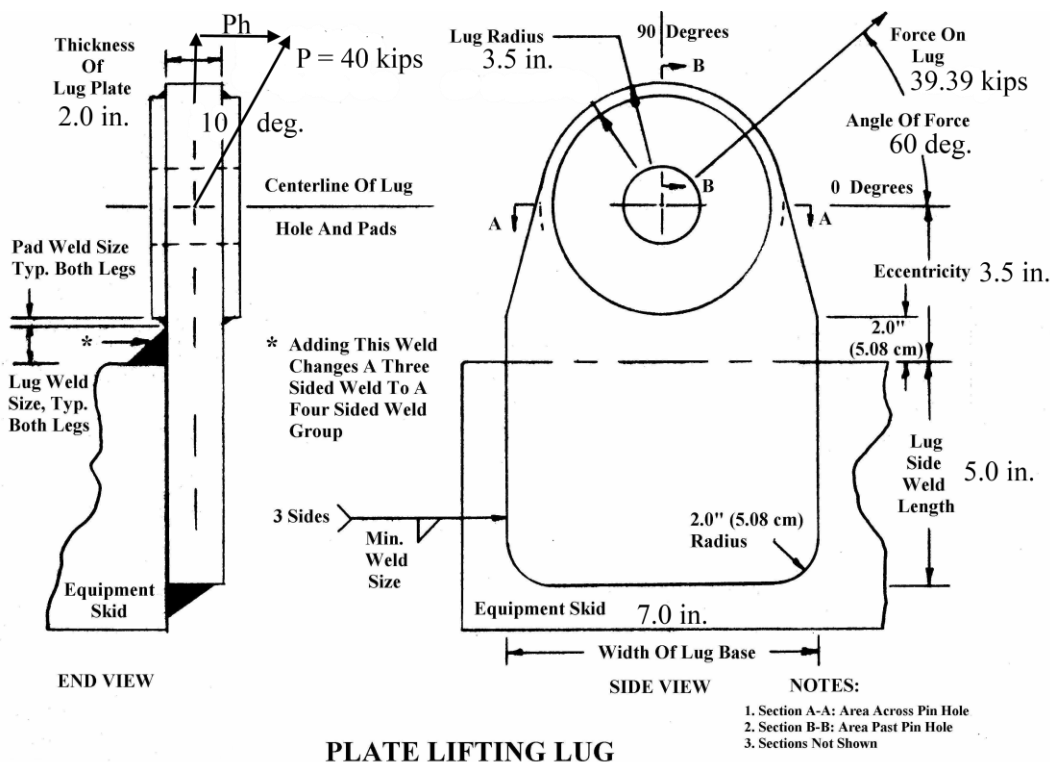

**NOW CALCULATE THE ADDITIONAL STRESS IMPOSED ON THE LUG PLATE DUE TO THE SIDE LOAD:**

Refer to the printout and drawing above.

Where:

The force on the lug P at 10 deg. angle	= 40.00 kips
The horizontal component of the side load force Ph	= 6.95 kips
The force on the lug in the strong axis	= 39.39 kips
The angle of the force in the strong axis of the lug	= 60 deg.
Angle of the force in the weak axis	= 10 deg.
The eccentricity	= 3.5 inches
The allowable yield stress Fb in bending of the A36 plate	= 36 ksi*.6
The allowable yield stress Ft in tension of the A36 plate	= 21.6 ksi
The section modulus Sx for bending in the strong axis is 2" (thickness of the lug) * 7" (width of the lug)^2/6	= 16.33 cu. in.
The section modulus Sz for bending in the weak axis is 7" * 2^2/6	= 4.67 cu. in.
Bending moment Mz in the weak axis is 3.5" eccentricity * 6.95 kips Ph * 1.8 (Impact factor IF)	= 43.79 k-in.
Bending stress fbz in the weak axis is 43.79 k-in/4.67 cu.in.	= 9.38 ksi
The ratio of the the bending stress fbz to the allowable bending stress is 9.38/21.6	= 0.43

From the printout above note that the combined stress for the lug plate without any side load = 0.56  
 To get the total combined stress on the lug plate in the strong axis and the weak axis, add  $0.56 + 0.43 = 0.99 < 1.0$  ==> Good

∴ (therefore) the lug plate is good for the 10° side load

**NOW CALCULATE THE ADDITIONAL WELD REQUIRED FOR THE PLATE LUG AT THE TOP OF THE EQUIPMENT SKID DUE TO THE SIDE LOAD:**

Calculate the vertical force F that the weld on the back side of the lug will see due to the side load.

$$F = 43.79 \text{ k-in bending moment} / 1'' (\frac{1}{2} \text{ width of lug}) = 43.79 \text{ k}$$

Now, the additional weld required due to the side load is

$$43.79 \text{ k} / (14.85 \text{ k/in} * 7'' \text{ width of lug}) = 0.42$$

From the printout above, the weld requirement for a three sided weld = 0.86

From the printout above, the weld requirement for a four sided weld = 0.54

∴ if the plate lug is to be welded on using a three sided weld, then all welds should be increased to  $0.86 + 0.42 = 1.28 \text{ in.}$

If the plate lug is to be welded on using a four sided weld, then only the top horizontal weld should be increased to  $0.54 + 0.42 = 0.96 \text{ in.}$

Recommend using a 1 1/4'' & 1.0 in respectively

**EXAMPLE 2: A plate lug used as a top head lug.**

**NOTE:**

1. This lug design was taken from #6 Presentation
2. Two cases will be considered to determine worst case:
  - a. with the vessel in the set position (in the vertical) where the load to each lug = 87.90 kips
  - b. with the vessel at the initial pick position (in the horizontal) where the load = 52.74 kips

**CASE A:**

The first printout is for the vessel in the vertical at set where the load to each lug = 87.90 kips

And the combined stress of the lug plate is 0.24 without any side load. This is for vertical tension only.

## PROGRAM TO DESIGN A PLATE TYPE LIFTING LUG v.02

COMPANY: CSI

PROJECT: Aneth Gas Plant

ITEM NUMBER: Tower 2 @ SET

Crosby G2130x55	▼	Select a metric shackle from the lookup table based on the force on the lug or click the SHACKLE button to enter your own shackle and lug data.	
4.13	in	Shackle Inside Width at Pin	
5.69	in	Shackle Eye Diameter	
2.80	in	Shackle Pin Diameter	
2.93	in	Lug Pin Hole Diameter	Recommend hole be 0.13" or > than shackle pin dia.
5.00	in	Lug Radius	
1.50	in	Lug Plate Thickness	
20.00	in	Lug Plate Width at Base	Minimum value of 2*radius of lug
14.00	in	Lug Side weld length	Recommend using min. 0.7 * lug plate width
.50	in	Lug Pad Thickness	Input zero if pads are not required
4.50	in	Lug Pad Radius	Input zero if pads are not required
18.00	in	Lug Eccentricity	
87.90	kips	Force on the Lug	
90.00	deg	Angle of the Force on the Lug	Measured from the horizontal
36.00	ksi	Yield Stress of the Lug Material	Fy
14.85	kips/in	Allowable Force on the Weld	Use 10.91 for LH60 or 14.85 for LH70
1.80		Impact factor, IF	Recommend that a minimum 1.8 impact factor be used

### OUTPUT:

#### Checking combined stress of the lug plate

30.00	in^2	Area of Lug Plate at Base	
100.00	in^3	Section modulus of the lug plate at the base	
0.00	ksi	Bending stress of the lug plate fb, actual	
5.27	ksi	Tension stress of the lug plate ft, actual	
21.60	ksi	Allowable bending and tension stress, Fb & Ft	
0.24		Combined stress of the lug plate. Must be less than 1.0	

48.00	in	Area of the weld
0.00	kips/in	Horizontal component of twist
0.00	kips/in	Vertical component of twist
1.83	kips/in	Tension force on the weld
0.00	kips/in	Shearing force on the weld
1.83	kips/in	Resultant Force on the weld
0.22	in	Minimum weld size

13

MAX. @ IPP

**Checking the lug weld size for a FOUR sided weld, with the weld treated as a line**

<del>68.00</del>	<del>in</del>	<del>Area of the weld</del>
<del>0.00</del>	<del>kips/in</del>	<del>Horizontal component of twist</del>
<del>0.00</del>	<del>kips/in</del>	<del>Vertical component of twist</del>
<del>1.29</del>	<del>kips/in</del>	<del>Tension force on the weld</del>
<del>0.00</del>	<del>kips/in</del>	<del>Shearing force on the weld</del>
<del>1.29</del>	<del>kips/in</del>	<del>Resultant Force on the weld</del>
<del>0.16</del>	<del>in</del>	<del>Minimum weld size</del>

**Checking bearing at the pin hole**

37.67	ksi	Bearing stress of the lug without pads
22.60	ksi	Bearing stress with pads attached
32.40	ksi	Allowable bearing stress
17.58	kips	Load per pad
0.12	in	Pad weld size, min.

GOOD

USE 1/4" WELD

**Checking end area of the lug across the pin hole**

9.77	in <sup>2</sup>	End area required across the pin hole
4.59	in	Maximum effective lug radius. Used to calculate the max. allowable end area
11.72	in <sup>2</sup>	Maximum effective end area

GOOD

**Checking end area of the lug past the pin hole**

6.51	in <sup>2</sup>	Area required past the pin hole
8.34	in <sup>2</sup>	Actual end area
7.72	in <sup>2</sup>	Maximum allowable end area

GOOD

Calculated by [www.maximumreach.com](http://www.maximumreach.com)

4/13/2012

The drawing below shows the details of the plate lug (In this application, it is called a top head lug) that agrees with the printout above and also shows the side load information, ie, 88.02 kips at a 3° side load angle. Note that bending will be just above the kicker plate, ie, 6" down from the centerline of the lug hole.

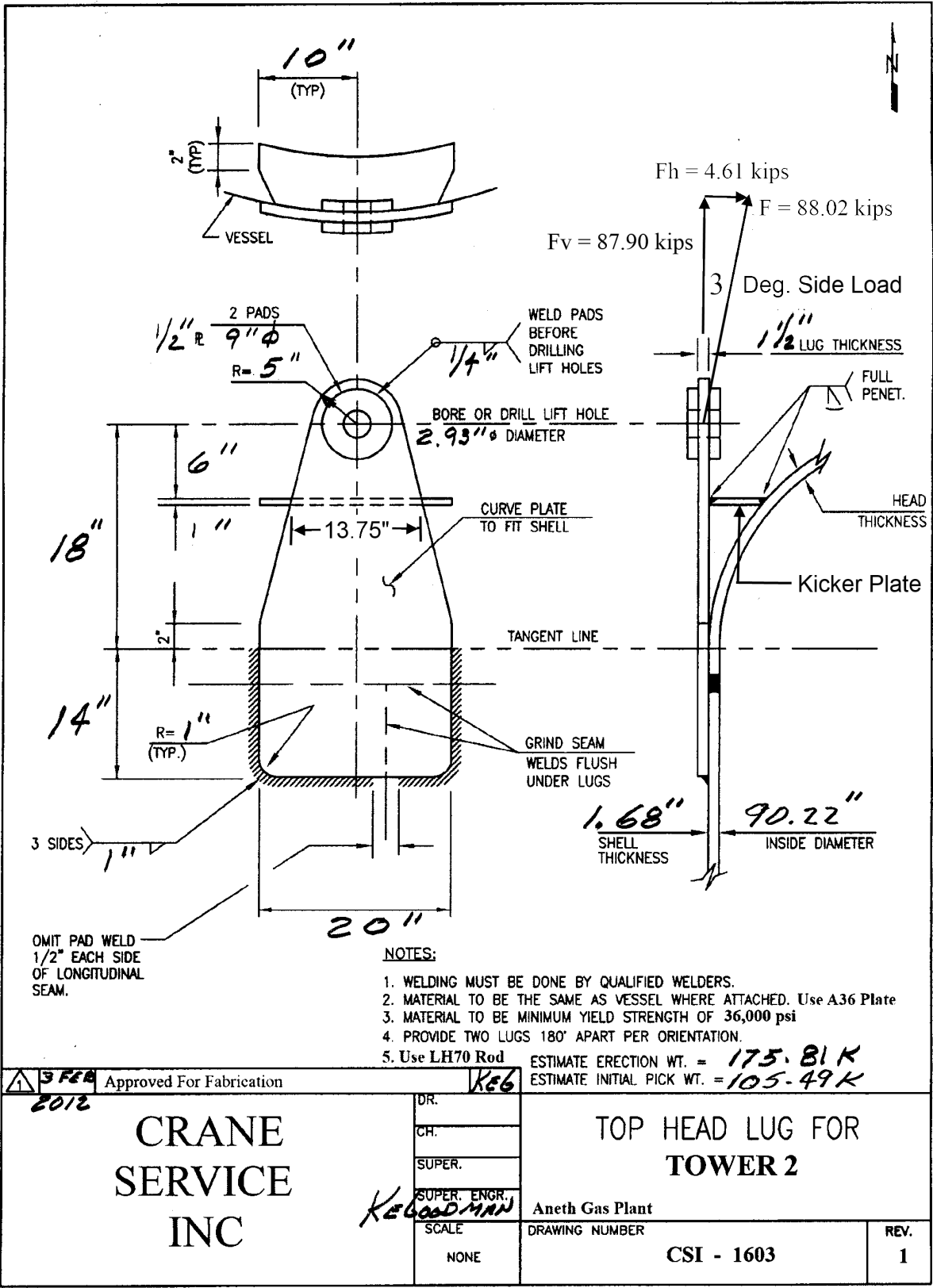

PROMISES AND AGREES TO RETURN IT UPON REQUEST AND AGREES THAT IT SHALL NOT BE REPRODUCED, COPIED, LENT OR OTHERWISE DISPOSED OF DIRECTLY OR INDIRECTLY FOR ANY PURPOSE OTHER THAN THAT FOR WHICH IT IS LOANED. THIS DRAWING HAS NOT BEEN PUBLISHED AND IS THE SOLE PROPERTY OF CRANE SERVICE INC. AND IS LOANED TO THE BORROWER FOR HIS CONFIDENTIAL USE ONLY. AND IN CONSIDERATION OF THE LOAN OF THIS DRAWING, THE BORROWER

OMIT PAD WELD  
1/2" EACH SIDE  
OF LONGITUDINAL  
SEAM.

**NOTES:**

1. WELDING MUST BE DONE BY QUALIFIED WELDERS.
2. MATERIAL TO BE THE SAME AS VESSEL WHERE ATTACHED. Use A36 Plate
3. MATERIAL TO BE MINIMUM YIELD STRENGTH OF 36,000 psi
4. PROVIDE TWO LUGS 180° APART PER ORIENTATION.
5. Use LH70 Rod

ESTIMATE ERECTION WT. = 175.81K  
ESTIMATE INITIAL PICK WT. = 105.49K

<b>CRANE SERVICE INC</b>	DR. <b>KEG</b>	<b>TOP HEAD LUG FOR TOWER 2</b>  <b>Aneth Gas Plant</b> DRAWING NUMBER <b>CSI - 1603</b>	
	CH.		
	SUPER.		
	SUPER. ENGR. <b>KEGOODMAN</b>		
	SCALE NONE		
		REV. <b>1</b>	

**FIRST CALCULATE THE COMBINED STRESS AT THE KICKER PLATE DUE TO THE VERTICAL LOAD ONLY:**

The tension stress at the kicker plate is

$$87.90 \text{ kips vertical load} * 1.8 \text{ IF} / 1.5'' \text{ lug thickness} * 13.75'' \text{ lug width at the kicker plate} = 7.67 \text{ ksi}$$

The combined stress is the ratio of the actual tension stress/allowable tension stress and is

$$7.67 \text{ ksi} / 21.60 \text{ ksi} = 0.36$$

Note that this is up from the combined stress of 0.24 calculated at the tangent line

**NOW CALCULATE THE ADDITIONAL STRESS IMPOSED ON THE LUG PLATE DUE TO THE SIDE LOAD:**

Refer to the printout and drawing above.

Where:

The force F on the lug in the weak axis	= 88.02 kips
The horizontal component of the side load force Fh	= 4.61 kips
The angle of the force in the strong axis of the lug	= 90 deg.
Angle of the force in the weak axis	= 3 deg.
The width of the kicker plate	= 13.75''
The allowable yield stress Fb in bending of the A36 plate = 36 ksi*0.6	= 21.6 ksi
The section modulus Sz for bending in the weak axis at the kicker plate is 13.75'' * 1.5'' <sup>2</sup> /6	= 5.16 cu. in.
Bending moment in the weak axis is 6'' eccentricity * 4.61 kips Fh * 1.8 (Impact factor IF)	= 49.79 k-in
Bending stress fbz in the weak axis is 49.79 k-in/5.16 cu. in.	= 9.66 ksi
The ratio of the bending stress fbz to the allowable bending stress is 9.66 / 21.60	= 0.45
From the calculation above for the combined tension stress for the lug plate at the kicker plate without any side load	= 0.36
To get the total combined stress on the lug plate in the strong axis and the weak axis, add 0.36 + 0.45 = 0.81 < 1.0	==> Good

∴ the lug plate in the set position is good for the 3° side load shown

**NOW CHECK THE WELD AT THE KICKER PLATE TO SEE IF IT HAS SUFFICIENT CAPACITY DUE TO THE SIDE LOAD:**

In this case, the weld between the lug plate and the shell is not affected by the side load, so only the weld at the kicker plate needs to be checked. Note that the 1'' kicker plate is welded to the shell and to the lug plate with a full pent. weld. Therefore, it is equivalent to a 1'' weld size.

The capacity of the 1'' weld is

$$14.85 \text{ kips/in} * 13.75'' \text{ of weld length} = 204.19 \text{ kips}$$

$$204.19 \text{ kips} > 4.61 \text{ kips side load} \text{ =====> Good}$$

∴ The lug plate and weld at the kicker plate are good for the 3° side load with the vessel in the vertical.



**CASE B:**

The next printout is for the vessel in the IPP (the horizontal position) where the vertical load to each lug

= 52.74 kips

And the combined stress of the lug plate is 0.79 without any side load. This is for the IPP load only.

**PROGRAM TO DESIGN A PLATE TYPE LIFTING LUG v.02**

**COMPANY:** CSI

**PROJECT:** Aneth Gas Plant

**ITEM NUMBER:** Tower 2 @ IPP

Crosby G2130x55	▼	Select a metric shackle from the lookup table based on the force on the lug or click the SHACKLE button to enter your own shackle and lug data.	
4.13	in	Shackle Inside Width at Pin	
5.69	in	Shackle Eye Diameter	
2.80	in	Shackle Pin Diameter	
2.93	in	Lug Pin Hole Diameter	Recommend hole be 0.13" or > than shackle pin dia.
5.00	in	Lug Radius	
1.50	in	Lug Plate Thickness	
20.00	in	Lug Plate Width at Base	Minimum value of 2*radius of lug
14.00	in	Lug Side weld length	Recommend using min. 0.7 * lug plate width
.50	in	Lug Pad Thickness	Input zero if pads are not required
4.50	in	Lug Pad Radius	Input zero if pads are not required
18.00	in	Lug Eccentricity	
52.74	kips	Force on the Lug	
0.00	deg	Angle of the Force on the Lug	Measured from the horizontal
36.00	ksi	Yield Stress of the Lug Material	Fy
14.85	kips/in	Allowable Force on the Weld	Use 10.91 for LH60 or 14.85 for LH70
1.80		Impact factor, IF	Recommend that a minimum 1.8 impact factor be used

**OUTPUT:**

**Checking combined stress of the lug plate**

30.00	in^2	Area of Lug Plate at Base	
100.00	in^3	Section modulus of the lug plate at the base	
17.09	ksi	Bending stress of the lug plate fb, actual	
0.00	ksi	Tension stress of the lug plate ft, actual	
21.60	ksi	Allowable bending and tension stress, Fb & Ft	
0.79		Combined stress of the lug plate. Must be less than 1.0	<b>GOOD</b>

**Checking the lug weld size for a THREE sided weld, with the weld treated as a line**

11

48.00	in	Area of the weld
3.27	kips/in	Horizontal component of twist
3.25	kips/in	Vertical component of twist
0.00	kips/in	Tension force on the weld
1.10	kips/in	Shearing force on the weld
5.44	kips/in	Resultant Force on the weld
0.66	in	Minimum weld size

GOOD Use 1"

**Checking the lug weld size for a FOUR sided weld, with the weld treated as a line**

68.00	in	Area of the weld
2.01	kips/in	Horizontal component of twist
1.41	kips/in	Vertical component of twist
0.00	kips/in	Tension force on the weld
0.78	kips/in	Shearing force on the weld
2.97	kips/in	Resultant Force on the weld
0.36	in	Minimum weld size

**Checking bearing at the pin hole**

22.60	ksi	Bearing stress of the lug without pads
13.56	ksi	Bearing stress with pads attached
32.40	ksi	Allowable bearing stress
10.55	kips	Load per pad
0.07	in	Pad weld size, min.

MAX. @ SET  
GOOD

USE 1/4"

**Checking end area of the lug across the pin hole**

5.86	in <sup>2</sup>	End area required across the pin hole
4.59	in	Maximum effective lug radius. Used to calculate the max. allowable end area
11.72	in <sup>2</sup>	Maximum effective end area

GOOD

**Checking end area of the lug past the pin hole**

3.91	in <sup>2</sup>	Area required past the pin hole
8.34	in <sup>2</sup>	Actual end area
7.72	in <sup>2</sup>	Maximum allowable end area

MAX. @ SET

GOOD

**NOW CALCULATE THE ADDITIONAL STRESS IMPOSED ON THE LUG PLATE DUE TO THE SIDE LOAD:**

Refer to the printout above. A drawing was not made for this case but the information is summarized below:

Where:

The force F on the lug in the weak axis	= 52.81 kips
The horizontal component of the side load force Fh	= 2.76 kips
The angle of the force in the strong axis of the lug	= 0.0 deg.
Angle of the force in the weak axis	= 3 deg.
The width of the kicker plate	= 13.75"
The allowable yield stress Fb in bending of the A36 plate = 36 ksi*0.6	= 21.6 ksi
The section modulus Sz for bending in the weak axis at the kicker plate is 13.75" * 1.5" <sup>2</sup> /6	= 5.16 cu. in.
Bending moment in the weak axis is 6" eccentricity * 2.76 kips Fh * 1.8 (Impact factor IF)	= 29.81 k-in
Bending stress fbz in the weak axis is 29.81 k-in/5.16 cu. in.	= 5.78 ksi
The ratio of the bending stress fbz to the allowable bending stress is 5.78 / 21.60	= 0.27
From the printout above for the combined tension stress for the lug plate without any side load	= 0.79
To get the total combined stress on the lug plate in the strong axis and the weak axis, add 0.79 + 0.27 = 1.06 ≈ 1.0	==> Good

∴ the lug plate in the IPP is good for the 3° side load shown

**NOW CHECK THE WELD AT THE KICKER PLATE TO SEE IF IT HAS SUFFICIENT CAPACITY DUE TO THE SIDE LOAD:**

As with the vessel in the set position, the weld between the lug plate and the shell is not affected by the side load, so only the weld at the kicker plate needs to be checked. Note that the 1" kicker plate is welded to the shell and to the lug plate with a full pent. weld. Therefore, it is equivalent to a 1" weld size.

The capacity of the 1" weld is

$$14.85 \text{ kips/in} * 13.75 \text{ " of weld length} = 204.19 \text{ kips}$$

$$204.19 \text{ kips} > 4.61 \text{ kips side load} =====> \text{ Good}$$

∴ The lug plate and weld at the kicker plate are good for the 3° side load with the vessel in the IPP.

**COMMENTS:**

- Note that the side load was taken at the center of the lug hole. If the shackle pin is a tight fit in the lug hole, then the side lug force will occur at the bail of the shackle (probably more to the side of the bail) instead of at the center of the lug hole and the eccentricity or moment arm should be taken from the kicker plate up to bearing on the shackle bail or there about, ie, for a 55 Te shackle the eccentricity would then be +/- 11.90" + 6" = +/- 17.90". In this example, the additional eccentricity would over stress the lug plate. The proof of this is left up to the reader.
- This is why it is strongly recommended that plate lugs not be side loaded, because if they are it is usually hard to determine the correct moment arm to use to be conservative.

**END OF PLATE LUG CALCULATION FOR A SIDE LOAD**